

ASSEMBLY INSTRUCTIONS

FOR

DYNALITE PRO SERIES FRONT HUB KIT WITH 11.75" DIAMETER VENTED ROTOR

1965 - 1969 FORD MUSTANG (DRUM / DISC SPINDLE)

PART NUMBER GROUP

140-4304-B

WARNING

INSTALLATION OF THIS KIT SHOULD **ONLY** BE PERFORMED BY PERSONS EXPERIENCED IN THE INSTALLATION AND PROPER OPERATION OF DISC BRAKE SYSTEMS. IT IS THE RESPONSIBILITY OF THE PERSON INSTALLING ANY BRAKE COMPONENT OR KIT TO DETERMINE THE SUITABILITY OF THE COMPONENT OR KIT FOR THAT PARTICULAR APPLICATION.

RACING EQUIPMENT AND BRAKES MUST BE MAINTAINED AND SHOULD BE CHECKED REGULARLY FOR FATIGUE, DAMAGE AND WEAR.



WARNING

DO NOT OPERATE ANY VEHICLE ON UNTESTED BRAKES!

BEFORE OPERATING VEHICLE, TEST THE BRAKES UNDER CONTROLLED CONDITIONS IN A SAFE AREA. TEST THE SYSTEM IN STATIC CONDITIONS FOR PROPER PEDAL HEIGHT AND THE ABILITY TO HOLD PRESSURE BEFORE ATTEMPTING TO MOVE THE VEHICLE. MAKE SEVERAL STOPS IN A SAFE AREA AT SLOW SPEEDS AND GRADUALLY WORK UP TO NORMAL OPERATING CONDITIONS. **ALWAYS** UTILIZE SAFETY RESTRAINT SYSTEMS AND ALL OTHER REQUIRED SAFETY EQUIPMENT WHILE OPERATING THE VEHICLE.

IMPORTANT

READ THE DISCLAIMER OF WARRANTY INCLUDED IN THE KIT.

WARNING: Some cleaners may stain or remove the finish on brake system components. Test the cleaner on a hidden portion of the component before general use.

Dual Kit Configurations

This kit has been designed for use with both the disc brake or the drum brake configuration of vehicle. The only difference is in how the Wilwood caliper mounting bracket is installed. The same bracket is used for both configurations; the disc brake version utilizes three mounting holes while the drum brake application uses four mounting holes (see Figure 1). For your convenience we have supplied bolt kits for both applications (see parts list and Figure 2 as necessary, item(s) 2A and 2B). Use the bolt kit that is applicable to your vehicle and disregard the other one.

Caliper Mounting Bracket - Mounting Hole Designations

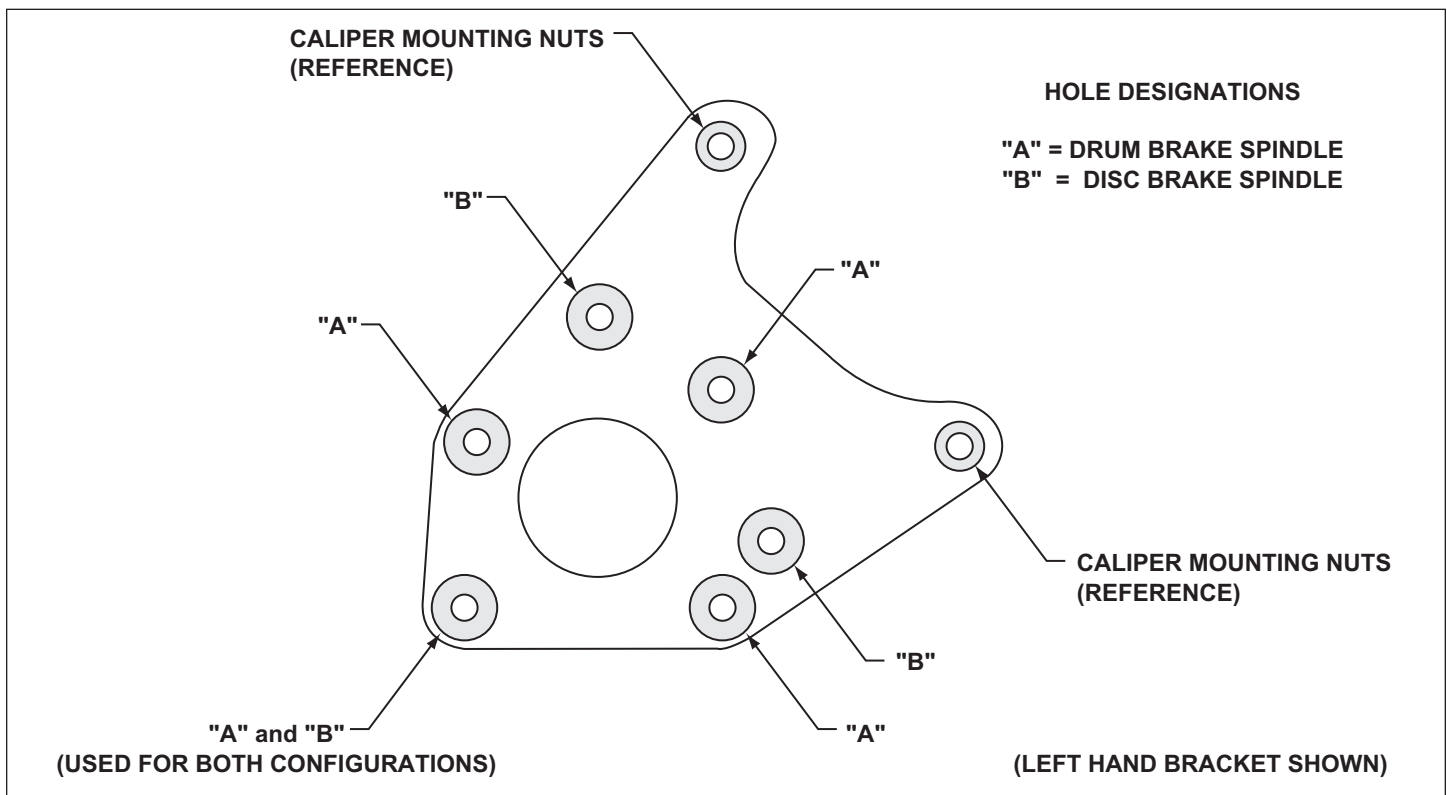

Figure 1. Wilwood Caliper Mounting Bracket

Important Notice - Disc Brake Applications Only

Before any tear-down or disassembly begins, some modifications are required to the stock steering arm/spindle. This entails drilling out and re-tapping the three holes in the spindle that are utilized to mount the Wilwood caliper mounting bracket. It is recommended that these modifications be performed by a qualified machine shop. Please keep in mind that this may require a substantial amount of time (more than a day). Therefore, the vehicle may be inoperable for longer than anticipated.

Important Notice - Read This First

Before any tear-down or disassembly begins, review the following information:

- Review the wheel clearance diagram (figure 3, page 5) to verify that there is adequate clearance with the wheels you will be using with the installation. This kit will result in the wheels being moved out approximately .75" beyond the stock location.
- Front brake kits do not include flex lines. OEM brake lines will not adapt to Wilwood calipers. Check the assembly instructions, or associated components section for brake line recommendations before assembly. In addition, Wilwood offers an extensive listing of brake lines and fittings on our web site: www.wilwood.com.
- Due to OEM production differences and other variations from vehicle to vehicle, the fastener hardware and other components in this kit may not be suitable for a specific application or vehicle.
- It is the responsibility of the purchaser and installer of this kit to verify suitability / fitment of all components and ensure all fasteners and hardware achieve complete and proper engagement. Improper or inadequate engagement can lead to component failure.

General Information and Disassembly Instructions

General Information:

Installation of this kit should **ONLY** be performed by persons experienced in the installation and proper operation of disc brake systems. Before assembling the Wilwood front disc brake kit, double check the following items to ensure a trouble-free installation. Also, please read these instructions thoroughly to be sure you have a complete understanding of the procedure involved before work is begun.

- Make sure this is the correct kit to match the exact make and model year of the vehicles spindle (i.e., hubs for a 1960 Ford spindle will not fit a 1969 Ford spindle). On some models of disc brake spindles there are "ears" where the OEM calipers were mounted and these "ears" interfere with the assembly of the Wilwood disc brake kit. If it becomes necessary to remove these "ears", remove as little as possible being careful not to cut away any of the mounting holes that may be required to bolt on the caliper mounting bracket.
- Verify the hub stud pattern in this kit matches the stud pattern of the vehicles wheels.
- Inspect the package contents against the parts list (below) to ensure that all components and hardware are included.

Disassembly Instructions:

- Disassemble the original equipment front brakes:

Raise the front wheels off the ground. Support the front suspension by placing jack stands under the lower control arms. The lower control arms **MUST** be supported. The vehicle's weight must be on jack stands. The vehicle must not be supported by a car jack or hoist.

Remove the center cap, cotter pin, nut lock and the wheel bearing nut and washer. Save the wheel bearing nut and nut lock. Remove the brake drum and hub assembly, including the wheel bearings. Disconnect the brake hoses from the brake line at the body. Remove the two upper backing plate retaining nuts and bolts. Remove the two lower ball joint to spindle nuts and bolts. The backing plate, spindle and ball joint will now separate. Remove the brake backing plate and shoes as an assembly. Reinstall the front ball joint bolt and nut. Do not tighten at this time. Do not reinstall the rear bolt and nut.

Exploded Assembly Diagram and Parts List

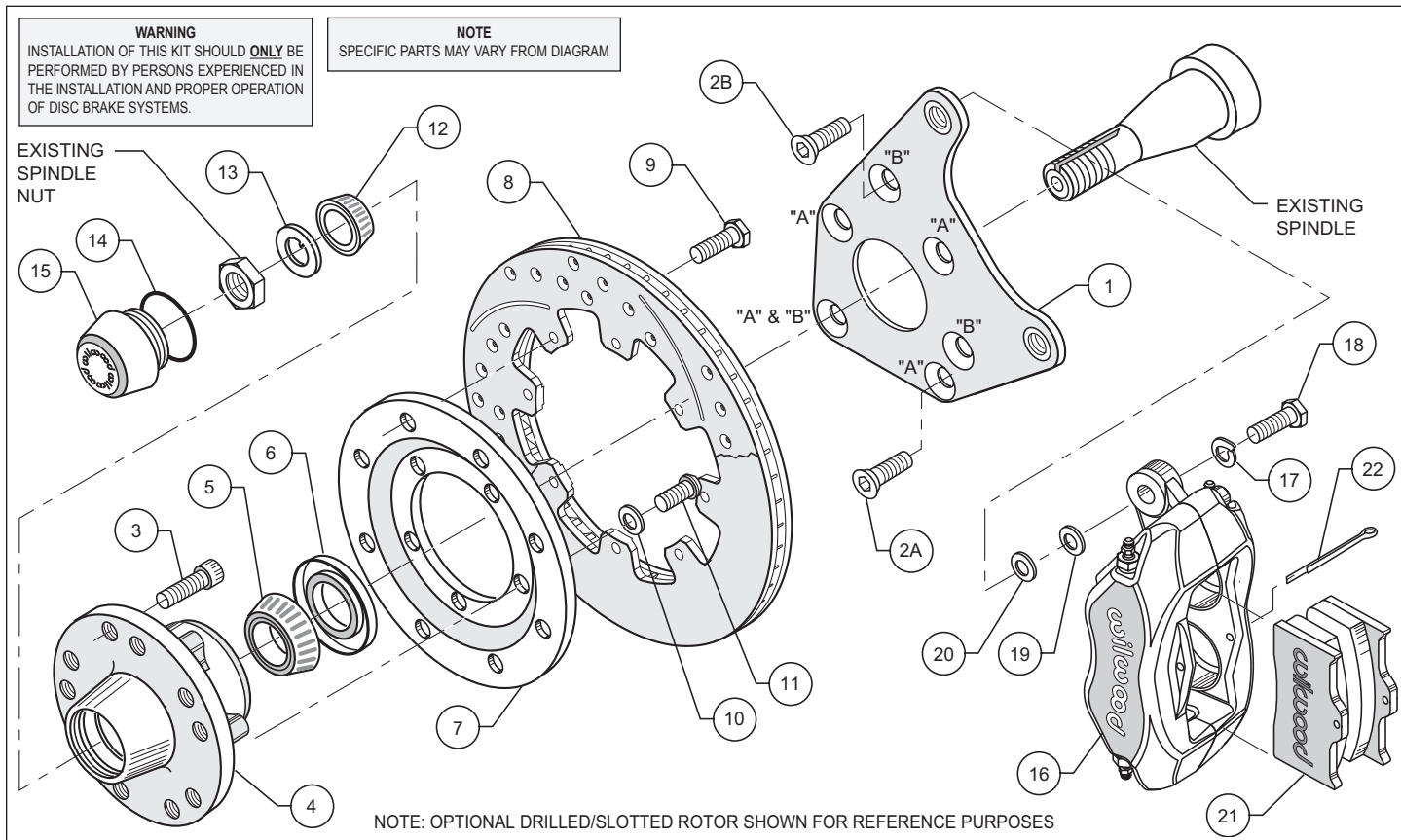

Figure 2. Typical Installation Configuration

<u>ITEM NO.</u>	<u>PART NO.</u>	<u>DESCRIPTION</u>	<u>QTY</u>
1	249-4302/03	Bracket Kit, Caliper Mounting	1
2A	230-4305	Bolt Kit, Bracket, Drum Brake Spindle	1
2B	230-4306	Bolt Kit, Bracket, Disc Brake Spindle	1
3	230-2187	Stud, 1/2-20 x 1.75 Long, SHCS	10
4	270-7274	Hub Assembly	2
5	370-0879	Cone, Inner Bearing	2
6	380-0885	Seal, Grease	2
7	300-3099	Adapter, Rotor	2
8	160-5841	Rotor, .81" Thk x 11.75" Dia, 8 x 7.00" Bolt Circle	2
8A	160-7101/02	Rotor, Drilled and Slotted (pair, one each, left and right)	2
9	230-2043	Bolt, 5/16-18 x 0.75 Long, Hex Head	16
10	240-2510	Washer, 3/8 inch	10
11	230-3784	Bolt, 3/8-16 x 1.0 Long, Torx	10
12	370-0877	Cone, Outer Bearing	2
13	240-2283	Washer, 3/4 Spindle	2
14	211-1674	O-ring	2
15	270-2158	Cap, Dust	2
16	120-6816	Caliper, Forged Dynalite	2
16A	120-6796-P	Caliper, Forged Dynalite, Polished	2
17	240-0140	Washer, Lock, 3/8 inch	4
18	230-0228	Bolt, 3/8-24 x 1.25 Long, Hex Head	4
19	240-1159	Shim, 0.032 inch Thick	16
20	240-3280	Washer, 1/2 Flat x .875 O.D. x .063 Long	8
21	150-8850K	Pad, BP-10, Axle Set	1
22	180-0055S	Pin, Cotter	2

NOTES: Part Number 230-3829 Bolt Kit, adapter plate to hub, includes part numbers 230-3784 and 240-2510
 Part Number 230-3484 Bolt Kit, rotor to adapter plate, includes part number 230-2043
 Part Number 230-0204 Bolt Kit, caliper to bracket, includes part numbers 230-0228, 240-0140 and 240-1159
 Item 8A is an optional item and is available in the (D) drilled kits
 Item 16A is an optional item and is available in the (P) polished kits

Steering Arm / Spindle Modifications

Disc Brake Configuration Only:

These modifications should be performed by a qualified machinist and completed before assembly of the Wilwood disc brake kit begins. Using the caliper mounting bracket as a template (refer to figure 1 as necessary), locate and verify the three original stock holes on the steering arm that need to be modified. Drill a .332 diameter hole through all three holes, then tap 3/8-24 UNF (fine thread). Countersink the holes to .438 x 90°.

Assembly Instructions

Assembly Instructions (numbers in parenthesis refer to the part list/diagram on pages 3 and 4): **CAUTION:** All mounting bolts must fully engage insert nuts. Be sure to check that all bolts are either flush or protruding through flanged side of insert nut after shimming.

- As mentioned before, this kit uses the same mounting bracket (1) for both the drum and disc brake spindle. The drum version utilizes four mounting bolts (designated with a "A"), while the disc only requires three (designated with a "B"). Refer to figure 1 and figure 2 as required for the basic installation position of the bracket and the "A" and "B" reference designations (these designations are not physically marked on the bracket, they are referenced on the drawings for your convenience) and align using the three or four holes (as applicable) to the face plate of the steering arm. Install bolts (2A or 2B) through caliper mounting bracket (1) into steering arm, finger tighten only. After you are positive of the bracket (1) alignment, remove the mounting bolts (2A or 2B) one at a time and Apply red *Loctite*® 271 to bolt threads (2A or 2B), then reinstall. Torque bolts 2A or 2B to 30 ft-lb. **NOTE:** Be sure the heads of the bracket (1) insert nuts are facing outward toward the wheel.

- Install wheel studs (3) into the hub (4). Torque to 77 ft-lb. **NOTE:** There are two (2) five lug patterns in the hub (5 x 4.50 and 5 x 4.75). Make sure of the correct hole pattern for the correct wheel application before installing studs into hub.

- Pack the large inner bearing cone (5) with high temperature disc brake bearing grease (available from your local auto parts store) and install into the backside of the hub (4).

- Install the grease seal (6) by pressing into the backside of the hub (4).

- Attach rotor adapter plate (7) to rotor (8) using bolts (9). Torque bolts (9) to 180 in-lb. Safety wire bolts (9) using standard 0.032 inch diameter stainless steel safety wire as shown in Figure 4. Please refer to Wilwood's data sheet DS-386 (available at www.wilwood.org/ds386.pdf) for complete safety wire installation instructions. **NOTE:** Dished side of adapter plate (7) should face hub (4). The machined tab side of the iron rotor (8) should face the adapter plate (7).

- Mount the adapter/rotor assembly (7 and 8) to the hub (4) using lock washers (10) and bolts (11). Torque bolts (11) to 22 ft-lb. Safety wire bolts (11).

- Pack the small outer bearing cone (12) with high temperature disc brake bearing grease and install into front of hub (4). Slide the hub/rotor assembly (4 and 8) with outer bearing cone (12) onto the spindle. Secure using spindle washer (13), stock adjusting nut and nut locking device. Adjust bearings per Original Equipment Manufacturer (OEM) specifications.

- Install the o-ring (14) and then the dust cap (15) onto the hub (4). Friction created by the o-ring (14) on the dust cap (15) keeps it from unscrewing.

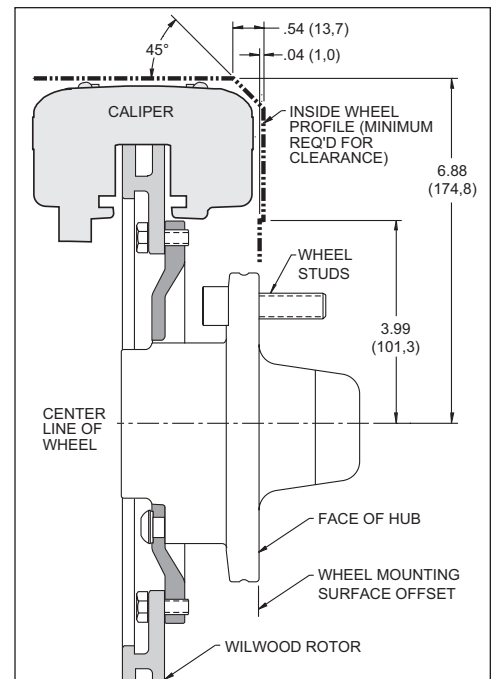

Figure 3. Wheel Clearance Diagram

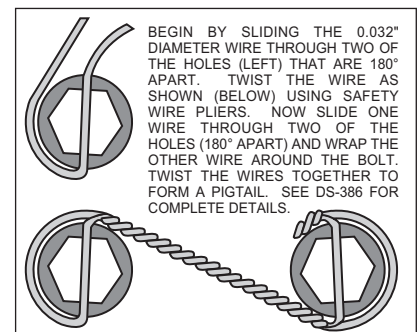

Figure 4. Safety Wire Diagram

Assembly Instructions (Continued)

•**NOTE:** Please reference the caution statement at the beginning of the assembly instructions. With the bleed screws pointing up, mount the caliper (16) onto the caliper bracket (1) using lock washers (17) and bolts (18). Place two .063 thick flat washers (20) between the caliper (16) and the caliper mounting bracket (1) before sliding the mounting bolts (18) all the way into the caliper mounting bracket (1), finger tighten only. View the rotor (8) through the top opening of the caliper (16). The rotor (8) should be aligned in the center of the caliper (16). If not, adjust the caliper (16) by using 0.032 inch thick shims (19) placed between the caliper mounting bracket (1) and the caliper spacer washer (20). Finger tighten and recheck alignment. Use as many shim washers (19) as necessary to achieve the correct alignment. Apply red *Loctite*® 271 to bolt threads (18) and torque to 30 ft-lb. Safety wire caliper bolts (18).

•Install the disc brake pads (21) and secure using cotter pin (22).

•**NOTE:** OEM rubber brake hoses will not adapt to Wilwood calipers and should not be used. The caliper inlet fitting is a 1/8-27 NPT. Use steel adapter fittings at the caliper, either straight, 45 or 90 degree and enough steel braided line to allow for full suspension travel and turning radius, lock to lock. **Carefully route lines to prevent contact with moving suspension, brake, or wheel components.** Periodically check hose and components for any wear. Wilwood brake and hose kits are designed for use in many different vehicle applications and it is the installer's responsibility to properly route and ensure adequate clearance and retention for brake hose components.

•Bleed the brake system. Reference the general information and recommendations on the last page for proper bleeding instructions.

Balancing the Brake Bias on 4 Wheel Disc Vehicles

•OE Style or Single Mount Race Pedal with Tandem Outlet Master Cylinder:

Front to rear caliper piston sizes, rotor diameters, and pad compounds must be initially configured to provide the correct range of vehicle bias when using a single bore / tandem outlet master cylinder. If excessive rear brake bias is experienced, an inline adjustable proportioning valve can be used to decrease the rear line pressure to help bring the vehicle into balance. If excessive front brake bias is experienced, first consideration should be given to increasing the rear brake bias to bring the vehicle into overall balance.

•Race Pedal with Dual Master Cylinders and Balance Bar:

Master cylinders must be sized to match the calipers and allow the pedal balance bar to operate near the center of its travel. If it is not possible to fine tune the bias within the adjustable range of the balance bar, then consideration must be given to changing a master cylinder bore size or some other aspect of the brake system to bring the car into balance. Larger bore master cylinders will generate less pressure while decreasing pedal travel. Smaller bores master cylinders will generate higher line pressures with an increase in pedal travel.

Additional Information and Recommendations

• Fill and bleed the new system with Wilwood Hi-Temp^o 570 grade fluid or higher. For severe braking or sustained high heat operation, use Wilwood EXP 600 Plus Racing Brake Fluid. Used fluid must be completely flushed from the system to prevent contamination.
NOTE: Silicone DOT 5 brake fluid is **NOT** recommended.

• To properly bleed the brake system, begin with the caliper farthest from the master cylinder. Bleed the outboard bleed screw first, then the inboard. Repeat the procedure until all calipers in the system are bled, ending with the caliper closest to the master cylinder.
NOTE: When using a new master cylinder, it is important to bench bleed the master cylinder first.

• If the master cylinder is mounted lower than the disc brake calipers, some fluid flowback to the master cylinder reservoir may occur, creating a vacuum effect that retracts the caliper pistons into the housing. This will cause the pedal to go to the floor on the first stroke until it has “pumped up” and moved all the pistons out against the pad again. A Wilwood in-line two pound residual pressure valve, installed near the master cylinder will stop the fluid flowback and keep the pedal firm and responsive.

• Test the brake pedal. It should be firm, not spongy and stop at least 1 inch from the floor under heavy load.
 If the brake pedal is spongy, bleed the system again.

If the brake pedal is initially firm, but then sinks to the floor, check the system for fluid leaks. Correct the leaks (if applicable) and then bleed the system again.

If the brake pedal goes to the floor and continued bleeding of the system does not correct the problem, a master cylinder with increased capacity (larger bore diameter) will be required. Wilwood offers various lightweight master cylinders with large fluid displacement capacities.

• **NOTE:** With the installation of after market disc brakes, the wheel track may change depending on the application. Check your wheel offset before final assembly. Please see the warning box on page 3.

• On some models of disc brake spindles there are “ears” where the OEM calipers were mounted and these “ears” interfere with the assembly of the Wilwood disc brake kit. If it becomes necessary to remove these “ears”, remove as little as possible being careful not to cut away any of the mounting holes that may be required to bolt on the caliper mounting bracket.

• If after following the instructions, you still have difficulty in assembling or bleeding your Wilwood disc brakes, consult your local chassis builder, or retailer where the kit was purchased for further assistance.

PAD BEDDING PROCEDURE:

• Pump brakes at low speed to assure proper operation. On the race track, or other safe location, make a series of hard stops until some brake fade is experienced. Allow brakes to cool while driving at moderate speed to avoid use of the brakes. This process will properly burnish the brake pads, offering maximum performance.

Associated Components

PART NO.	DESCRIPTION
260-1874	Wilwood Residual Pressure Valve (2 lb for disc brakes)
260-1876	Wilwood Residual Pressure Valve (10 lb for drum brakes)
260-8419	Wilwood Proportioning Valve
290-0632	Wilwood Racing Brake Fluid (Hi-Temp ^o 570) (12 oz)
290-6209	Wilwood Racing Brake Fluid (EXP 600 Plus) (16.9 oz)
340-1285	Wilwood Floor Mount Brake Pedal (with balance bar)
340-1287	Wilwood Swing Mount Brake Pedal (with balance bar)
260-6764	Wilwood 3/4 inch High Volume Aluminum Master Cylinder
260-6765	Wilwood 7/8 inch High Volume Aluminum Master Cylinder
260-6766	Wilwood 1 inch High Volume Aluminum Master Cylinder
260-4893	1-1/16 inch Tandem Master Cylinder (aluminum housing)
250-2406	Mounting Bracket Kit (tandem master cylinder)
260-8555	Wilwood 1 inch Aluminum Tandem Chamber Master Cylinder
260-8556	Wilwood 1-1/8 inch Aluminum Tandem Chamber Master Cylinder
350-2038	1971 - 1973 Pinto Rack and Pinion (new, not rebuilt)
270-2016	Quick Release Steering Hub (3/4 inch shaft)
270-2017	Quick Release Steering Hub (5/8 inch shaft)
220-7056	Flexline Kit, Universal, 14 Inch, Domestic
220-7699	Flexline Kit, Universal, 16 Inch, Domestic
220-8307	Flexline Kit, Universal, 18 Inch, Domestic

Bolt Torque Specifications

BOLT SIZE	TORQUE
1/4-20	85 in-lb
1/4-28	103 in-lb
5/16-18	180 in-lb
5/16-24	198 in-lb
3/8-16	22 ft-lb
3/8-24	30 ft-lb
7/16-14	42 ft-lb
7/16-20	47 ft-lb
1/2-13	65 ft-lb
1/2-20	77 ft-lb
9/16-12	95 ft-lb
9/16-18	105 ft-lb
5/8-11	110 ft-lb
5/8-18	120 ft-lb

NOTE: This bolt torque specification list is for use with specific grades of bolts as supplied in the particular Wilwood kit and is not intended as a guide for any other application.