

# ASSEMBLY INSTRUCTIONS

FOR

## FORGED SUPERLITE 4 BIG BRAKE FRONT HUB KIT WITH 12.19" DIAMETER VENTED ROTOR

Pinto (1974-1980) / Mustang II (1974-1978) Disc Brake Spindles

PART NUMBER GROUP

**140-9482**

### WARNING

INSTALLATION OF THIS KIT SHOULD **ONLY** BE PERFORMED BY PERSONS EXPERIENCED IN THE INSTALLATION AND PROPER OPERATION OF DISC BRAKE SYSTEMS. IT IS THE RESPONSIBILITY OF THE PERSON INSTALLING ANY BRAKE COMPONENT OR KIT TO DETERMINE THE SUITABILITY OF THE COMPONENT OR KIT FOR THAT PARTICULAR APPLICATION.

RACING EQUIPMENT AND BRAKES MUST BE MAINTAINED AND SHOULD BE CHECKED REGULARLY FOR FATIGUE, DAMAGE AND WEAR.



### WARNING

#### **DO NOT OPERATE ANY VEHICLE ON UNTESTED BRAKES!**

BEFORE OPERATING VEHICLE, TEST THE BRAKES UNDER CONTROLLED CONDITIONS IN A SAFE AREA. TEST THE SYSTEM IN STATIC CONDITIONS FOR PROPER PEDAL HEIGHT AND THE ABILITY TO HOLD PRESSURE BEFORE ATTEMPTING TO MOVE THE VEHICLE. MAKE SEVERAL STOPS IN A SAFE AREA AT SLOW SPEEDS AND GRADUALLY WORK UP TO NORMAL OPERATING CONDITIONS. **ALWAYS** UTILIZE SAFETY RESTRAINT SYSTEMS AND ALL OTHER REQUIRED SAFETY EQUIPMENT WHILE OPERATING THE VEHICLE.

### IMPORTANT

READ THE DISCLAIMER OF WARRANTY INCLUDED IN THE KIT.

**WARNING:** Some cleaners may stain or remove the finish on brake system components. Test the cleaner on a hidden portion of the component before general use.

## Important Notice - Read This First

Before any tear-down or disassembly begins, review the following information:

- Review the wheel clearance diagram (figure 2, page 4) to verify that there is adequate clearance with the wheels you will be using with the installation.
- Front brake kits do not include flex lines. OEM brake lines will not adapt to Wilwood calipers. Check the assembly instructions, or associated components section for brake line recommendations before assembly. In addition, Wilwood offers an extensive listing of brake lines and fittings on our web site: [www.wilwood.com](http://www.wilwood.com).
- Due to OEM production differences and other variations from vehicle to vehicle, the fastener hardware and other components in this kit may not be suitable for a specific application or vehicle.
- It is the responsibility of the purchaser and installer of this kit to verify suitability / fitment of all components and ensure all fasteners and hardware achieve complete and proper engagement. Improper or inadequate engagement can lead to component failure.

## Exploded Assembly Diagram

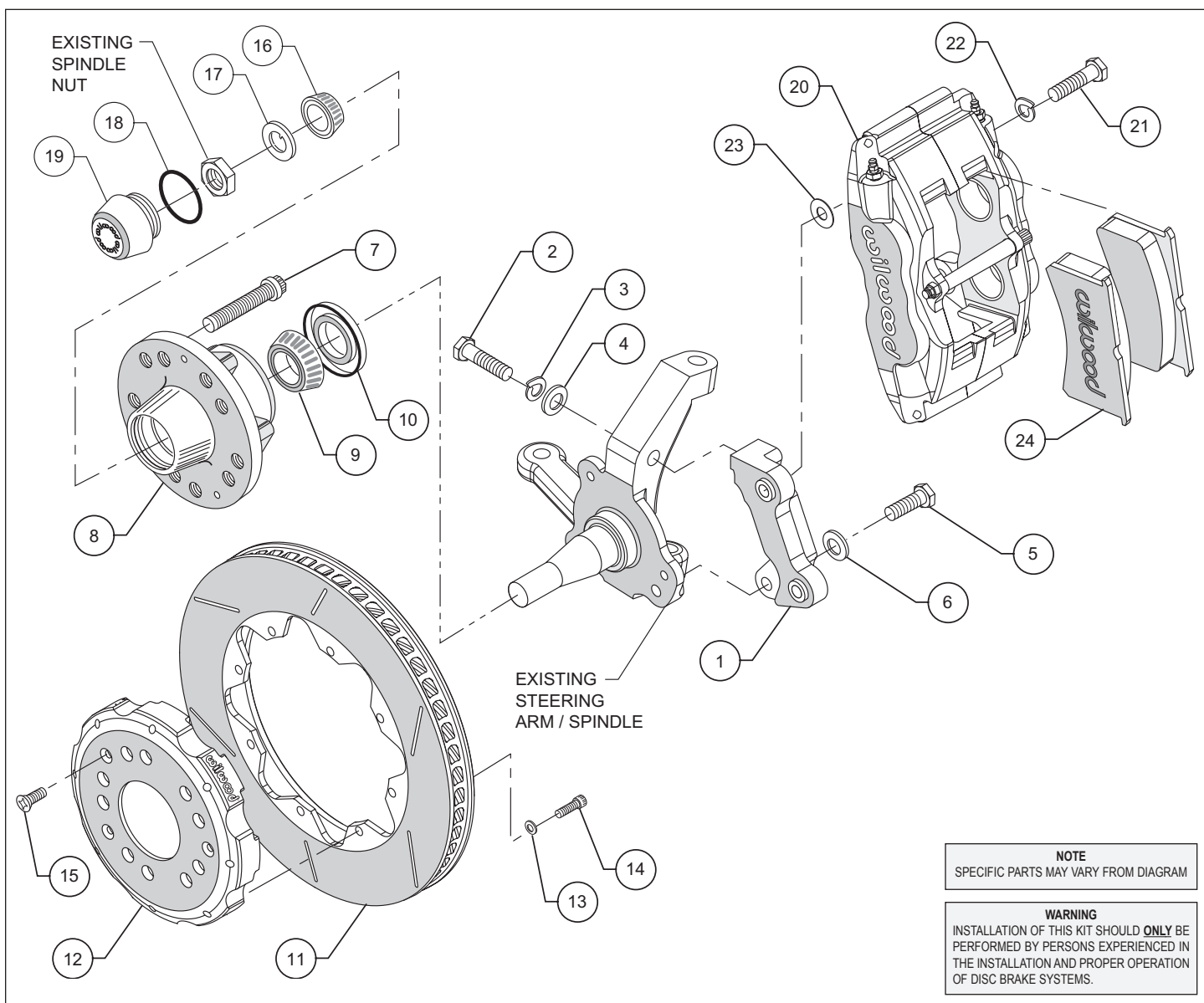

Figure 1. Typical Installation Configuration

## General Information

Installation of this kit should **ONLY** be performed by persons experienced in the installation and proper operation of disc brake systems. Before assembling the Wilwood front disc brake kit, double check the following items to ensure a trouble-free installation. Also, please read these instructions thoroughly to be sure you have a complete understanding of the procedure involved before work is begun.

- Make sure this is the correct kit to match the exact make and model year of the vehicles spindle (i.e., hubs for a 1960 Ford spindle will not fit a 1973 Ford spindle).
- Verify the hub stud pattern in this kit matches the stud pattern of the vehicles wheels. There are two (5 x 4.50" and 5 x 4.75") bolt circle patterns. The one applicable to this kit is the one with the smaller 5 x 4.50" stud pattern.
- Verify your wheel clearance using Figure 2.
- Inspect the package contents against the parts list (below) to ensure that all components and hardware are included.

## Parts List

<u>ITEM NO.</u>	<u>PART NO.</u>	<u>DESCRIPTION</u>	<u>QTY</u>
1	249-9483/84	Bracket Kit, Caliper Mounting (left and right)	2
2	230-9531	Bolt, 1/2-13 x 2.00 Long, HHCS	2
3	240-0818	Washer, Lock, .500 I.D. x .88 O.D.	2
4	240-0976	Washer, .53 I.D. x 1.06 O.D.	2
5	230-9458	Bolt, 7/16-14 x 1.50 Long, HHCS	2
6	240-0476	Washer, .477 I.D. x .922 O.D.	2
7	230-6959	Stud, 1/2-20 x 2.00 Long, 12 PTCS	10
8	270-9486	Hub Assembly	2
9	370-0884	Cone, Inner Bearing	2
10	380-0885	Seal, Grease	2
11	160-2526/27	Rotor, GT 1.25" Thk x 12.19" Dia, 8 x 7.00" Bolt Circle (left and right)	2
12	170-8320	Hat, (2) 5 x 4.50", .935" offset, 8 x 7.00" Bolt Circle	2
13	240-0541	Washer, .329 I.D. x .561 O.D. x .056 Thick	16
14	230-3960	Bolt, 5/16-18 x 1.00 Long, 12 PTCS	16
15	230-7029	Bolt, 1/4-20 x .50 Long, FHCS	6
16	370-0882	Cone, Outer Bearing	2
17	240-2444	Washer, 7/8 Spindle	2
18	211-1674	O-ring	2
19	270-9380D	Cap, Dust	2
20	120-7429-R/L	Caliper, Forged Superlite	2
21	230-6381	Bolt, 7/16-20 x 1.75 Long, HXHD	4
22	230-0139	Washer, Lock, .438 I.D. x .769 O.D.	4
23	240-1848	Washer, .441 I.D. x 1.003 O.D. x .030 Thick	16
24	150-8855K	Pad, BP-10, Axle Set	1

### NOTES:

Part Number 230-9532 Bolt Kit, caliper mounting bracket to spindle, includes part numbers 230-9531, 230-9458, 240-0818, 240-0976 & 240-0476

Part Number 230-6365 Bolt Kit, rotor to hat, includes part numbers 230-3960 and 240-0541

Part Number 230-7032 Bolt Kit, hub to hat, includes part number 230-7029

Part Number 230-7031 Bolt Kit, caliper to bracket, includes part numbers 230-6381, 240-0139 and 240-1848

Wilwood offers an optional Braided Stainless Steel Hose Kit. Order part number 220-9481 (not included in kit)

## Disassembly / Assembly Instructions

### Disassembly Instructions:

- Disassemble the original equipment front brakes:

Raise the front wheels off the ground. Support the front suspension by placing jack stands under the lower control arms. The lower control arms **MUST** be supported. The vehicle's weight must be on jack stands. The vehicle must not be supported by a car jack or hoist.

Disconnect the brake hoses from the brake line at the body. Insert a plug or fitting to prevent excessive fluid leakage during installation. Remove caliper from OEM bracket and remove the caliper assembly along with the pads. Remove the center cap, cotter pin, nut lock and the wheel bearing nut and washer. Remove brake rotor and hub assembly. Remove the three dust plate bolts then remove the dust plate from the spindle (dust plate will not be reused). Remove the OEM caliper bracket from the spindle by removing the top and bottom bolts.

**Assembly Instructions** (numbers in parenthesis refer to the part list/diagram on the preceding pages): **CAUTION:** All mounting bolts must fully engage insert nuts. Be sure to check that all bolts are either flush or protruding through flanged side of insert nut after shimming.

- The caliper mount bracket assembly (1) should be installed first with clean, dry threads on the mounting bolts. Install the bracket by sliding bolt (2) through lock washer (3) and flat washer (4) from the side through the spindle support and into the top of the caliper mounting bracket (1). Slide bolt (5) through washer (6) from a 90° degree angle thru the mounting bracket and into the lower portion of the steering arm. The bracket must tighten squarely against the outboard side of the caliper mount bosses on the spindle body. Inspect for interference from casting irregularities, machining ridges, burrs, etc. Later, after the caliper, pad, and rotor alignment has been checked, and any necessary shims have been put in place, the mount bolts should be coated with red *Loctite*® 271 and bolt (2) torqued to 65 ft-lbs and bolt (5) torques to 42 ft-lbs.
- Install wheel studs (7) into the hub (8). Torque to 77 ft-lb. **NOTE:** There are two (2) five lug patterns in the hub (5 x 4.50 and 5 x 4.75). Make sure of the correct hole pattern for the correct wheel application before installing studs into hub. You must use the 5 x 4.50 pattern for this application.
- Pack the large inner bearing cone (9) with high temperature disc brake bearing grease (available from your local auto parts store) and install into the backside of the hub (8).
- Install the grease seal (10) by pressing into the backside of the hub (8).
- Pack the small outer bearing cone (16) with high temperature disc brake bearing grease and install into front of hub (8). Slide the hub assembly (7, 8, 9, 10 and 16) onto the spindle. Secure using spindle washer (17), stock adjusting nut and nut locking device. Adjust wheel bearing pre-load per Original Equipment manufacturer (OEM) specifications.
- Install the o-ring (18) on the dust cap (19), and screw dust cap assembly onto the hub (8). Friction created by the o-ring (18) on the dust cap (19) keeps it from unscrewing.
- With the stepped I.D. side of the rotor (11) facing away from the hat (12), bolt rotor (11) to hat (8) through the backside of the rotor using washers (13) and bolts (14). Torque bolts (14) to 180 **in-lb**. Safety wire bolts (14) using standard 0.032 inch diameter stainless steel safety wire as shown in Figure 3. Please refer to Wilwood's data sheet DS-386 (available at [www.wilwood.org/ds386.pdf](http://www.wilwood.org/ds386.pdf)) for complete safety wire installation instructions.

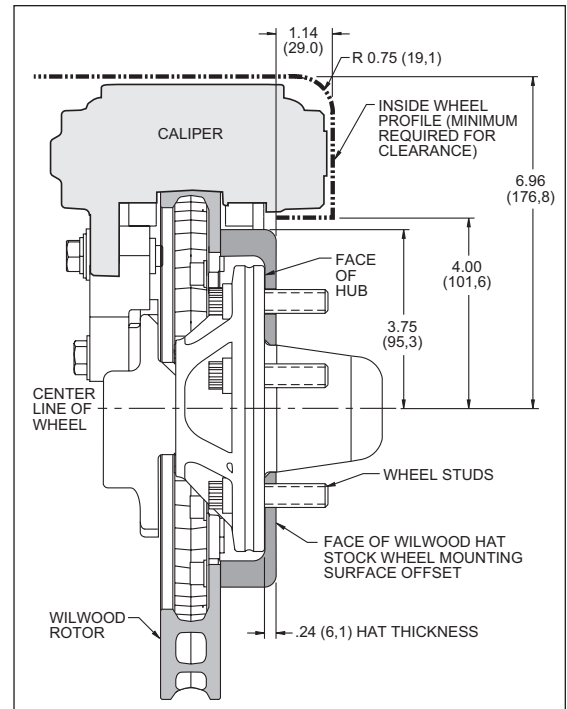

Figure 2. Wheel Clearance Diagram

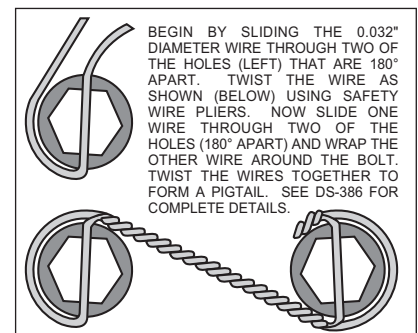

Figure 3. Safety Wire Diagram

## Assembly Instructions (Continued)

- Slide the rotor/hat assembly over the studs (7) being sure to utilize the larger stud hole size (.516) bolt circle pattern of the hat (12) onto the hub (8) while taking care to align the small countersunk holes in the hat (12) with the small threaded holes in the hub (8). Install three flat head socket head screws (15) through the small holes in the hat (12) and torque to 85 **in-lb**.

- NOTE:** Please reference the caution statement at the beginning of the assembly instructions. With the bleed screws pointing up, mount the caliper (20) onto the caliper bracket (1) using lock washers (22), and bolts (21). Place two .030 thick flat washers (23) between the caliper (20) and the caliper mounting bracket (1) before sliding the mounting bolts (21) all the way into the caliper mounting bracket (1). Finger tight only. View the rotor (11) through the top opening of the caliper (20). The rotor (11) should be aligned in the center of the caliper (20). If not, adjust the caliper (20) by adding or removing 0.030 inch thick shims (23) between the caliper mounting bracket (1) and the caliper (20). Finger tighten and recheck alignment. Use as many shim washers (23) as necessary to achieve the correct alignment. Apply red *Loctite*® 271 to bolt threads (21) and torque to 47 ft-lb. Safety wire caliper bolts (21).

- Remove the caliper bridge spacer and bolt. Install the disc brake pads (24), then reinstall the caliper bridge spacer and bolt.

- NOTE:** OEM rubber brake hoses will not adapt to Wilwood calipers and should not be used. The caliper inlet fitting is a 1/8-27 NPT. Use steel adapter fittings at the caliper, either straight, 45 or 90 degree and enough steel braided line to allow for full suspension travel and turning radius, lock to lock. **Carefully route lines to prevent contact with moving suspension, brake, or wheel components.** Periodically check hose and components for any wear. Wilwood brake and hose kits are designed for use in many different vehicle applications and it is the installer's responsibility to properly route the lines, ensuring adequate clearance and retention for brake hose components. Wilwood offers a hose kit, P/N 220-9481, which includes hoses, fittings, etc., in one package.

- Repeat assembly procedure for the other wheel.

- Bleed the brake system. Reference the general information and recommendations on the last page for proper bleeding instructions.

- Please read the following concerning balancing the brake bias on 4 wheel disc vehicles.

This Mustang II spindle kit can be operated using the stock OEM disc brake master cylinder. However, as with most suspension and rear brake and/or tire modifications (from OEM specifications), changing the brakes may alter the front to rear brake bias. Rear brakes should not lock up before the front. Brake system evaluation and tests should be performed by persons experienced in the installation and proper operation of brake systems. Evaluation and tests should be performed under controlled conditions. Start by making several stops from low speeds then gradually work up to higher speeds. Always utilize safety restraint systems while operating vehicle.

For competition or modified vehicles, please see biasing instructions below.

## Balancing the Brake Bias on 4 Wheel Disc Vehicles

### •OE Style or Single Mount Race Pedal with Tandem Outlet Master Cylinder:

Front to rear caliper piston sizes, rotor diameters, and pad compounds must be initially configured to provide the correct range of vehicle bias when using a single bore / tandem outlet master cylinder. If excessive rear brake bias is experienced, an inline adjustable proportioning valve can be used to decrease the rear line pressure to help bring the vehicle into balance. If excessive front brake bias is experienced, first consideration should be given to increasing the rear brake bias to bring the vehicle into overall balance.

### •Race Pedal with Dual Master Cylinders and Balance Bar:

Master cylinders must be sized to match the calipers and allow the pedal balance bar to operate near the center of its travel. If it is not possible to fine tune the bias within the adjustable range of the balance bar, then consideration must be given to changing a master cylinder bore size or some other aspect of the brake system to bring the car into balance. Larger bore master cylinders will generate less pressure while decreasing pedal travel. Smaller bores master cylinders will generate higher line pressures with an increase in pedal travel.

## Additional Information and Recommendations

• Fill and bleed the new system with Wilwood Hi-Temp<sup>o</sup> 570 grade fluid or higher. For severe braking or sustained high heat operation, use Wilwood EXP 600 Plus Racing Brake Fluid. Used fluid must be completely flushed from the system to prevent contamination.  
**NOTE:** Silicone DOT 5 brake fluid is **NOT** recommended.

• To properly bleed the brake system, begin with the caliper farthest from the master cylinder. Bleed the outboard bleed screw first, then the inboard. Repeat the procedure until all calipers in the system are bled, ending with the caliper closest to the master cylinder.  
**NOTE:** When using a new master cylinder, it is important to bench bleed the master cylinder first.

• If the master cylinder is mounted lower than the disc brake calipers, some fluid flowback to the master cylinder reservoir may occur, creating a vacuum effect that retracts the caliper pistons into the housing. This will cause the pedal to go to the floor on the first stroke until it has “pumped up” and moved all the pistons out against the pad again. A Wilwood in-line two pound residual pressure valve, installed near the master cylinder will stop the fluid flowback and keep the pedal firm and responsive.

• Test the brake pedal. It should be firm, not spongy and stop at least 1 inch from the floor under heavy load.  
 If the brake pedal is spongy, bleed the system again.

If the brake pedal is initially firm, but then sinks to the floor, check the system for fluid leaks. Correct the leaks (if applicable) and then bleed the system again.

If the brake pedal goes to the floor and continued bleeding of the system does not correct the problem, a master cylinder with increased capacity (larger bore diameter) will be required. Wilwood offers various lightweight master cylinders with large fluid displacement capacities.

• **NOTE:** With the installation of after market disc brakes, the wheel track may change depending on the application. Check your wheel offset before final assembly.

• On some models of disc brake spindles there are “ears” where the OEM calipers were mounted and these “ears” interfere with the assembly of the Wilwood disc brake kit. If it becomes necessary to remove these “ears”, remove as little material as possible being careful not to cut away any of the mounting holes that may be required to bolt on the caliper mounting bracket.

• If after following the instructions, you still have difficulty in assembling or bleeding your Wilwood disc brakes, consult your local chassis builder, or retailer where the kit was purchased for further assistance.

### **PAD BEDDING PROCEDURE:**

• Pump brakes at low speed to assure proper operation. Bed the brake pads on the vehicle in a safe location, by making a series of hard stops until some brake fade is experienced. Allow brakes to cool by driving at moderate speed and avoid use of the brakes. This process will properly burnish the brake pads, offering maximum performance.

### Associated Components

PART NO.	DESCRIPTION
260-1874	Wilwood Residual Pressure Valve (2 lb for disc brakes)
260-1876	Wilwood Residual Pressure Valve (10 lb for drum brakes)
260-8419	Wilwood Proportioning Valve
290-0632	Wilwood Racing Brake Fluid (Hi-Temp <sup>o</sup> 570) (12 oz)
290-6209	Wilwood Racing Brake Fluid (EXP 600 Plus) (16.9 oz)
340-1285	Wilwood Floor Mount Brake Pedal (with balance bar)
340-1287	Wilwood Swing Mount Brake Pedal (with balance bar)
260-6764	Wilwood 3/4 inch High Volume Aluminum Master Cylinder
260-6765	Wilwood 7/8 inch High Volume Aluminum Master Cylinder
260-6766	Wilwood 1 inch High Volume Aluminum Master Cylinder
260-4893	1-1/16 inch Tandem Master Cylinder (aluminum housing)
250-2406	Mounting Bracket Kit (tandem master cylinder)
260-8555	Wilwood 1 inch Aluminum Tandem Chamber Master Cylinder
260-8556	Wilwood 1-1/8 inch Aluminum Tandem Chamber Master Cylinder
350-2038	1971 - 1973 Pinto Rack and Pinion (new, not rebuilt)
270-2016	Quick Release Steering Hub (3/4 inch shaft)
270-2017	Quick Release Steering Hub (5/8 inch shaft)
220-9481	Flexline Kit, Superformance Cobra

### Bolt Torque Specifications

BOLT SIZE	TORQUE
1/4-20	85 in-lb
1/4-28	103 in-lb
5/16-18	180 in-lb
5/16-24	198 in-lb
3/8-16	22 ft-lb
3/8-24	30 ft-lb
7/16-14	42 ft-lb
7/16-20	47 ft-lb
1/2-13	65 ft-lb
1/2-20	77 ft-lb
9/16-12	95 ft-lb
9/16-18	105 ft-lb
5/8-11	110 ft-lb
5/8-18	120 ft-lb

**NOTE:** This bolt torque specification list is for use with specific grades of bolts as supplied in the particular Wilwood kit and is not intended as a guide for any other application.